

A revision of the Chinese *Catops* Paykull 1798 of the *Catops fuscus* species group (Coleoptera: Leiodidae: Cholevinae)

JAN RŮŽIČKA⁽¹⁾ & MICHEL PERREAU⁽²⁾

⁽¹⁾ Department of Ecology, Faculty of Environmental Sciences, Czech University of Life Sciences Prague, CZ-165 21 Praha 6, Czech Republic

⁽²⁾ Université Paris 7, IUT Paris Jussieu case 7139, 5 rue Thomas Mann, F-75205 Paris cedex 13, France

Abstract. Five species of the *Catops fuscus* species group are reported from China. Three species are newly described: *C. hlisnikovskyi* n. sp. from the Beijing municipality and Jiangsu province, *C. schuelkei* n. sp. from Sichuan and Yunnan provinces, and *C. smetanai* n. sp. from Sichuan and Yunnan provinces. Female of *C. sasajii* Nishikawa 2007 is described and the species is reported from Hubei, Sichuan and Yunnan provinces for the first time. *Catops nigricans* (Spence 1813) is reported for the first time from China (Xinjiang Uygur autonomous region). Important morphological characters are illustrated and the distribution of all species in China is mapped. Preliminary phylogenetic analysis separates (*C. hlisnikovskyi* n. sp. + *C. fuscus fuscus* Panzer 1794) as a sister clade to *C. nigricans* + (*C. sasajii* + (*C. schuelkei* n. sp. + *C. smetanai* n. sp.)), with *C. paramericus* Peck & Cook 2002 as outgroup.

Résumé. Révision des *Catops* chinois du groupe du *Catops fuscus* (Coleoptera : Leiodidae : Cholevinae). Cinq espèces appartenant au groupe du «*Catops fuscus*» sont signalées de Chine. Parmi elles, trois espèces nouvelles sont décrites : *C. hlisnikovskyi* n. sp. de la municipalité de Pékin et de la province de Jiangsu; *C. schuelkei* n. sp. des provinces du Sichuan et du Yunnan et *C. smetanai* n. sp., également du Sichuan et du Yunnan. La femelle de *C. sasajii* Nishikawa 2007 est décrite et cette espèce est signalée pour la première fois des provinces du Hubei, du Sichuan et du Yunnan. *Catops nigricans* (Spence 1813) est signalé pour la première fois de Chine (de la région autonome ouïgoure du Xinjiang). De nouveaux caractères morphologiques importants pour l'identification spécifique et la recherche des affinités phylogénétiques sont illustrés. La distribution géographique des espèces citées est synthétisée sur une carte. Une analyse phylogénétique préliminaire, avec *C. paramericus* Peck & Cook 2002 comme groupe externe, conduit à considérer les regroupements suivants (*C. hlisnikovskyi* n. sp. + *C. fuscus fuscus* Panzer 1794) comme groupe frère de *C. nigricans* + (*C. sasajii* + (*C. schuelkei* n. sp. + *C. smetanai* n. sp.)).

Keywords: *Catops fuscus* species group, taxonomy, morphology, new species, distribution.

Small carrion beetles of the genus *Catops* Paykull 1798 are the most numerous taxon of the subtribe Catopina, with nearly 130 described species distributed mainly through the Holarctic region (Perreau 2000, 2004; Peck & Cook 2002, Fresneda *et al.* 2006). The species of *Catops* are informally arranged in 16–17 species groups (Perreau 2000, Peck & Cook 2002). Jeannel (1936), who erected this grouping, based it mostly on western Palearctic species. Szymczakowski (1964) later added the Chinese and Oriental species of *Catops* represented by four species groups. Recently, Peck & Cook (2002) reviewed the species groups for Nearctic fauna of *Catops*.

Catops fuscus group was established by Jeannel (1936) for nine species distributed through Europe, northern Africa and Near East. European species of

this group were reviewed by Zwick (1981). The group now contains 20 species (Perreau 2000, Fresneda *et al.* 2006, Nishikawa 2007). Two western Palearctic species of the group extend into Middle Asia (Jeannel 1936, Perreau 2000): *C. nigriclavus* Gerhardt 1900 (northern Iran and southern Turkmenistan) and *C. fuscus fuscoides* Reitter 1909 (Afghanistan). The only three species of this species group known from South-East and East Asia are *C. fuscus repentinus* Szymczakowski 1962 from Japan, *C. loebli* Perreau 1988 from Nepal (Perreau 2000) and the recently described *C. sasajii* Nishikawa 2007 from China, Shaanxi province (Nishikawa 2007).

The biology of most species is not known in detail; the only exception is *Catops nigricans* (Spence 1813), which lives in nests of small mammals. Topp (1990, 2003) reported that *C. nigricans* is a monovoltine species that reproduces in the autumn, the larva develops through the winter months and the adult has an obligatory summer diapause; the synchronization of the

E-mail: ruzickajan@fzp.czu.cz, michel.perreau@univ-paris-diderot.fr

Accepté le 18 novembre 2010

annual cycle is achieved through several independent mechanisms fine-tuned by external factors such as photoperiod and temperature (Topp 1990, 2003). Several other European species of this group are also reported from nests of small mammals (Zwick 1981).

In the present paper, we revise the *Catops fuscus* species group in China, mostly based on specimens recently collected by Czech and German entomologists. Furthermore, we introduce useful structures on the male and female terminalia in addition to those used traditionally in descriptions (e.g., Szymczakowski 1964, Peck & Cook 2002); these characters are valuable for distinguishing taxa at the species level within *Catops* and probably applicable in a broader context within the subtribe Catopina.

Material and methods

Museum abbreviations

This study is based on the examination of 81 specimens from China, belonging to the *Catops fuscus* species group. The following abbreviations are used for institutions and private collections in which the specimens are deposited: APUC - Andreas Pütz collection, Eisenhüttenstadt, Germany; AWAC - Andreas Weigel collection, Pössneck, Germany; JRUC - Jan Růžička collection, Praha, Czech Republic; JVAC - Jiří Vávra collection, Ostrava, Czech Republic; MHNG - Muséum d'Histoire naturelle, Genève, Switzerland (Ivan Löbl, Giulio Cuccodoro); MPEC - Michel Perreau collection, Paris, France; MSCC - Michael Schülke collection, Berlin, Germany; NHMB - Naturhistorisches Museum, Basel, Switzerland (Michel Brancucci); NMEG - Naturkundemuseum, Erfurt, Germany (Matthias Hartmann); NMPC - J. Hlisenkovský collection in Národní muzeum, Praha, Czech Republic (Josef Jelínek, Jiří Hájek); RSCC - Rudolf Schuh collection, Wiener Neustadt, Austria.

Morphological analyses

The measurements were made using an ocular micrometer. Total body length (measured as the distance from labrum to apex of elytra in dorsal orthogonal view) is supplemented by the combined length of pronotum and elytra, as an exposed or retracted head (due to a different condition of the mounted

adult specimen) can introduce an error in the measurement. The length of the elytra is measured from the posterior angle of the scutellum to the apex of the elytra in dorsal orthogonal view. The morphological terms used in the descriptions generally follow Peck & Cook (2002); the terminology of female abdominal sclerites follows Deuve (2001). Male and female terminalia were studied after a short clearing in hot KOH, mounted in temporary glycerine mounts for line drawings. Aedeagi were placed in permanent mounts with DMHF (Bameul 1990) or Euparal for microphotographs. The abbreviation HT is used for a holotype throughout the text.

Specimens of the newly described species are provided with one red printed label "HOLOTYPUS or PARATYPUS (male or female symbol) / [Name of the taxon] sp. nov. / Jan Růžička et Michel Perreau det. 2005". Exact label data are cited for all specimens. Separate lines on labels are indicated by "/" and separate labels by "//". Our remarks and additional information are found in square brackets; [p] – preceding data within the quotes are printed; [hw] – preceding data within the quotes are hand-written.

Phylogenetic analysis

Phylogenetic analysis was performed using a matrix (Table 1) comprising six terminal taxa of the ingroup and 18 characters (16 parsimony informative characters) on external morphology. The analysis includes all Chinese species of the species group but excludes the European representatives except *C. fuscus fuscus* Panzer, 1794, as this group is in a need of revision for taxa known from the Mediterranean region and is not covered in this paper. Also, *C. loebli* and several undescribed species of this group from Nepal are not included as they will be treated separately (J. Růžička, unpubl.). The matrix was compiled in Winclada version 1.00.08 (Nixon 2002), and analysed by heuristic analysis using NONA ver. 2.0 (Goloboff 1999). All characters were equally weighted and multi-state characters were treated as unordered, ordered transformation series was coded only for character 2 (pronotum shape).

Catops paramericus Peck & Cook 2002 was selected as the outgroup. It is a member of the *C. americanus* species group, which was constituted and hypothesized to be a sister group to the remaining Nearctic *Catops* by Peck & Cook (2002).

The character scoring for the outgroup and additional species included is based on the following material:

Catops paramericus: 1 ♂ (JRUC): Canada: Ontario, Lake Nipissing, 26.VIII.1990, S. Snall leg.; 1 ♂, 2 ♀ (JRUC):

Table 1. Morphological data matrix for the phylogenetic analysis of the Chinese species of *Catops fuscus* species group. Female characters in *C. smetanai* n. sp. are coded as missing.

species/character	0	0	0	0	0	0	0	0	0	1	1	1	1	1	1	1	1	1
	1	2	3	4	5	6	7	8	9	0	1	2	3	4	5	6	7	8
<i>C. paramericus</i> (outgroup)	0	0	0	0	0	0	0	0	0	0	0	0	0	0	0	0	0	0
<i>C. fuscus fuscus</i>	0	1	1	0	0	0	1	1	1	1	1	0	0	0	1	3	1	0
<i>C. hlisenkovskiyi</i> n. sp.	1	1	1	1	0	0	1	0	1	1	1	1	1	1	3	2	1	1
<i>C. nigricans</i>	0	2	1	0	0	0	0	1	1	0	2	2	0	0	1	1	2	0
<i>C. sasajii</i>	1	2	1	1	1	1	0	2	2	0	2	2	0	0	1	3	3	1
<i>C. schuelkei</i> n. sp.	1	1	1	1	1	0	0	0	1	0	3	2	1	0	2	3	2	0
<i>C. smetanai</i> n. sp.	1	1	1	1	1	0	-	0	2	1	3	2	1	0	-	-	-	-

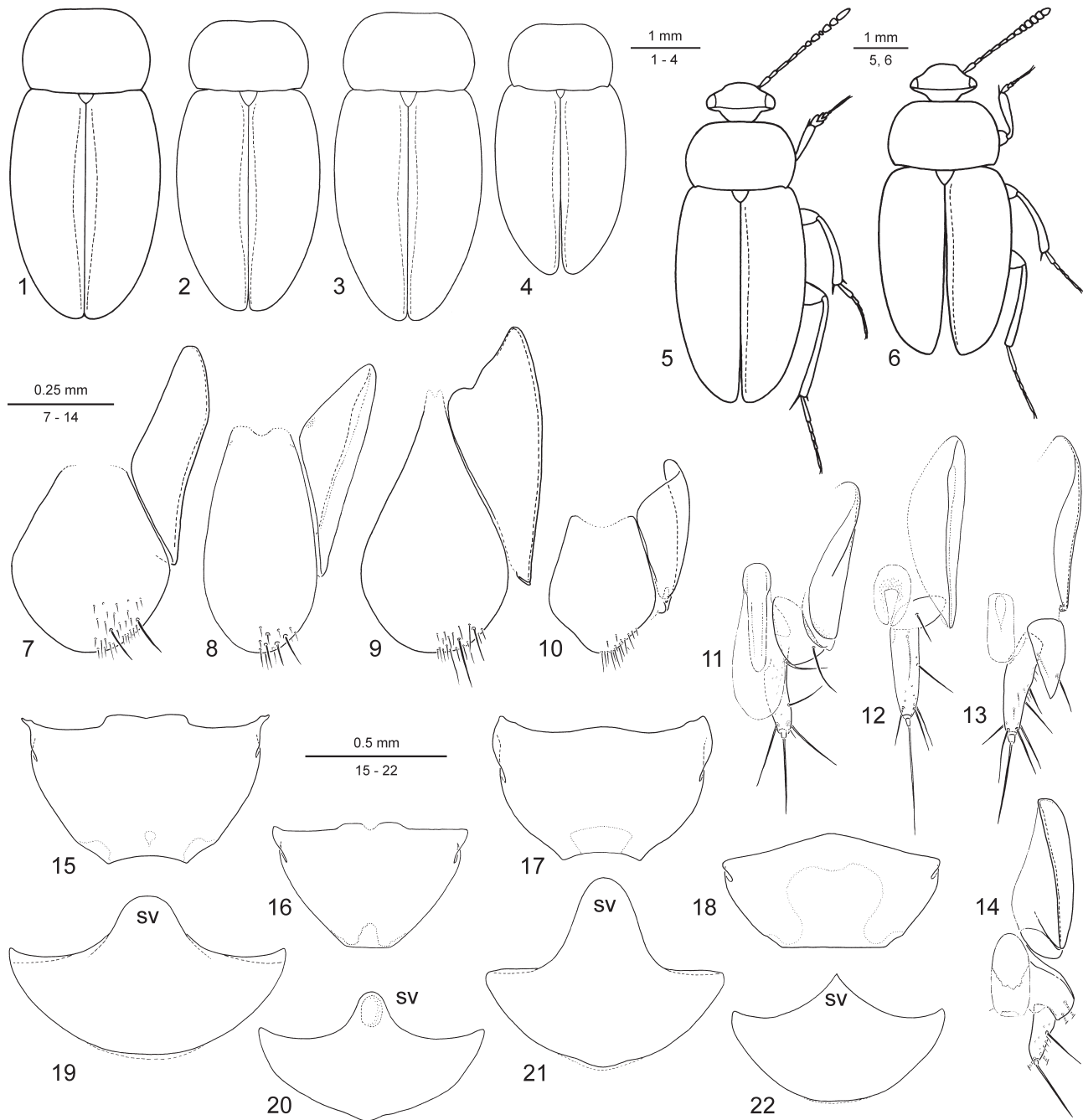
**Figures 1–22**

Habitus, dorsal view. **1**, *Catops schuelkei* n. sp., paratype ♂ (Meili Xue Shan, JRUC). **2**, *C. schuelkei* n. sp., paratype ♀ (Jinfo Shan, JRUC). **3**, *C. smetanai* n. sp., paratype ♂ (20 km N Sabdė, JRUC). **4**, *C. nigricans* (Spence) (Narat, JVAC). **5**, *C. sasajii* Nishikawa (93 km S Zhouzhi, APUC). **6**, *C. blisnikovskiyi* n. sp., holotype ♂ (Xiaolongmen, JRUC). Female tergite IX and epipleurite IX, dorsal view. **7**, *C. schuelkei*, paratype (Jinfo Shan, JRUC). **8**, *C. nigricans* (Spence) (Czech Republic: Bukovec Mt., JRUC). **9**, *C. sasajii* Nishikawa (93 km S Zhouzhi, JRUC). **10**, *C. blisnikovskiyi* n. sp., paratype (Xiaolongmen, JRUC). Female epipleurite IX, coxite and ventral sclerite, ventral view. **11**, *C. schuelkei* n. sp., paratype (Jinfo Shan, JRUC). **12**, *C. nigricans* (Spence) (Czech Republic: Bukovec Mt., JRUC). **13**, *C. sasajii* Nishikawa (93 km S Zhouzhi, JRUC). **14**, *C. blisnikovskiyi* n. sp., paratype (Xiaolongmen, JRUC). Female tergum VIII, dorsal view. **15**, *C. schuelkei*, paratype (Jinfo Shan, JRUC). **16**, *C. nigricans* (Spence) (Czech Republic: Bukovec Mt., JRUC). **17**, *C. sasajii* Nishikawa (93 km S Zhouzhi, JRUC). **18**, *C. blisnikovskiyi* n. sp., paratype (Xiaolongmen, JRUC). Female ventrite VIII, ventral view. sv = spiculum ventrale. **19**, *C. schuelkei*, paratype (Jinfo Shan, JRUC). **20**, *C. nigricans* (Spence) (Czech Republic: Bukovec Mt., JRUC). **21**, *C. sasajii* Nishikawa (93 km S Zhouzhi, JRUC). **22**, *C. blisnikovskiyi* n. sp., paratype (Xiaolongmen, JRUC).

Canada: Ontario, Thunder Bay, Powell Lakes, 13.VII.1980, M. Kaulbars leg., carrion, birch-poplar-pine forest.

Catops fuscus fuscus: 1 ♂ (JRUC): Slovakia: Plešivec env., Čertova diera cave, 27.II.1988, J. Růžička leg., wet entrance part of the cave; 1 ♀ (JRUC): Czech Republic, Jizerské hory Mts., Jizera Mt., 1050 m, J. Růžička & P. Vonička leg., 12.XI.1996–6.VI.1997, rock debris on southern slope, baited pitfall traps.

Character list

1. Body shape and size: (0) small, compact (smaller than 4.3 mm) (fig. 4); (1) large, more elongate (larger than 4.9 mm) (figs. 1–3, 5–6).
2. Shape of pronotal margin postero-laterally: (0) simple; (1) with narrow and very shallow emargination (figs. 1–3, 6); (2) with narrow and deep emargination (fig. 5).

3. Apex of female elytron: (0) rectangular, with small denticle; (1) regularly rounded (fig. 2).
4. Last antennomere: (0) oval (figs. 26–28); (1) very elongate (figs. 23–25, 29–30).
5. Antennal club: (0) compact, antennomeres VII and IX–X round or transverse and compact (figs. 26–28, 31–32); (1) elongate, antennomeres VII and IX–X very large, oblong to subtrapezoidal (figs. 23–25, 29–30).
6. Eyes: (0) of normal size, less than 0.21 times as wide in dorsal view as maximum width of head (fig. 6); very large, more than 0.27 times as wide in dorsal view as maximum width of head (fig. 5).
7. Protibia, outer margin (at least in female): (0) simple (figs. 33–36); (1) with numerous spines (figs. 37–38).

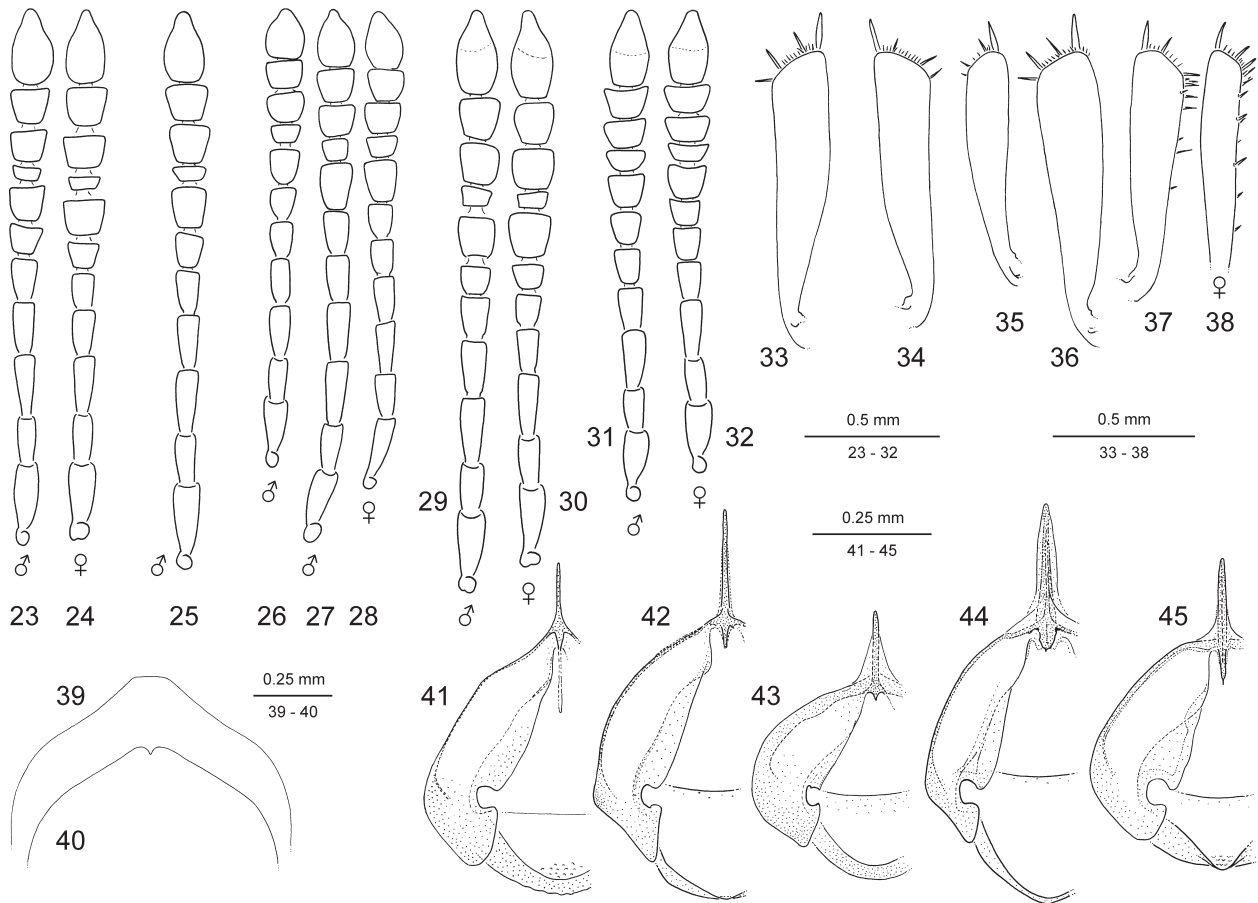

Figures 23–45

Right antenna, dorsal view. 23, *Catops schuelkei* n. sp., holotype ♂ (MSCC). 24, *C. schuelkei* n. sp., paratype ♀ (Meili Xue Shan, JRUC). 25, *C. smetanai* n. sp., holotype ♂ (MPEC). 26, *C. nigricans* (Spence), ♂ (Narat, JVAC). 27, *C. nigricans* (Spence), ♂ (Czech Republic: Bukovec Mt., JRUC). 28, *C. nigricans* (Spence), ♀ (Czech Republic: Bukovec Mt., JRUC). 29, *C. sasajii* Nishikawa, ♂ (93 km S Zhouzhi, APUC). 30, *C. sasajii* Nishikawa, ♀ (93 km S Zhouzhi, JRUC). 31, *C. blisnikovskiy* n. sp., holotype ♂ (JRUC). 32, *C. blisnikovskiy* n. sp., paratype ♀ (Xiaolongmen, JRUC). Protibia, dorsal view. 33, *C. schuelkei* n. sp., paratype ♂ (12 km SW Dequen, JRUC). 34, *C. smetanai* n. sp., holotype ♂ (MPEC). 35, *C. nigricans* (Spence), ♂ (Narat, JVAC). 36, *C. sasajii* Nishikawa, ♂ (93 km S Zhouzhi, JRUC). 37, *C. blisnikovskiy* n. sp., holotype ♂ (JRUC). 38, *C. blisnikovskiy* n. sp., paratype ♀ (Xiaolongmen, JRUC). Male ventrite VIII, ventral view. 39, *C. sasajii* Nishikawa (93 km S Zhouzhi, JRUC). 40, *C. nigricans* (Spence) (Narat, JVAC). Male genital segment ventrally. 41, *C. schuelkei* n. sp., paratype (Meili Xue Shan, JRUC). 42, *C. smetanai* n. sp., paratype (20 km N Sabd , JRUC). 43, *C. nigricans* (Spence) (Narat, JVAC). 44, *C. sasajii* Nishikawa (93 km S Zhouzhi, JRUC). 45, *C. blisnikovskiy* n. sp., holotype (JRUC).

8. Male ventrite VIII: (0) short, regularly rounded; (1) posteriorly elongate, with narrow emargination (fig. 40); (2) posteriorly elongate, wide, without apical emargination (fig. 39).
9. Genital segment with anterior part of spiculum gastrale: (0) short, not prominent; (1) moderately elongated (figs. 41, 45); (2) very elongated (figs. 42, 44).
10. Tergum of genital segment: (0) regularly rounded apically (figs. 41, 43); (1) V-shaped ventro-apically (figs. 42, 45).
11. Aedeagus, apex of median lobe in ventral view: (0) with slender and pointed tip; (1) widely triangular (fig. 54); (2) moderately wide, quadrangular and truncate (fig. 56); (3) very wide and laterally expanded (figs. 55, 57).
12. Apex of median lobe of aedeagus: (0) regular, pointed or rounded; (1) with dorsally elevated dentate lobe (fig. 46, 54); (2) more or less truncate with minute to obsolete median dent (figs. 55–57).
13. Valves of genital orifice: (0) rounded apically; (1) with acute apices.
14. Apex of paramere: (0) slender (figs. 49–53); (1) thick (fig. 47);
15. Female tergum VIII: (0) entirely sclerotized; (1) with small median desclerotization (fig. 16); (2) with small median and postero-lateral desclerotization (fig. 15); (3) most of median portion widely desclerotized (fig. 18).
16. Posterior margin of female tergum VIII: (0) regularly rounded; (1) slender, shortly truncate (fig. 16); (2) widely truncate (fig. 18); (3) widely emarginate (figs. 15, 17).
17. Spiculum ventrale on female ventrite VIII: (0) slender and elongated with oblong apex anteriorly; (1) widely triangular and sharply pointed anteriorly (fig. 22); (2) wide and short, regularly rounded anteriorly (figs. 19, 20); (3) wide and large, broadly rounded anteriorly (fig. 21).
18. Female coxite: (0) only with 4–5 large setae (figs. 11–12); (1) additional small setae present laterally (figs. 13–14).

Systematic part

Catops fuscus species group

Diagnosis. Adults of the species belonging to this species group can be characterized by the following combination of characters (according to Jeannel 1936, Zwick 1981, Růžička 1995, Salgado *et al.* 2008): (1) eyes fully developed, not reduced; (2) antenna long and slender, with weakly delimited club; antennomere VIII distinctly reduced, conical and symmetrical; antennomeres VII, IX and X large, wider than antennomeres VI and VIII, conical and usually slightly flattened dorso-ventrally; (3) male profemur without medial protuberance; (4) protibia sometimes with a row of spines on outer margin; (5) aedeagus of characteristic shape: apex usually with dorsally elevated complex structure, sometimes interrupted medially in apical view, see Zwick (1981) for details and figures concerning the Central European species, and usually with apex dorso-medially dentate. The shape of the antenna (character 2) and the modification of the apex of aedeagus (character 5) can be considered as synapomorphies of this species group.

The Chinese species of this group (with the exception of *C. nigricans*) can be differentiated from other Chinese *Catops* also by their extraordinary large body size (4.7–6.3 mm). The only

other *Catops* of comparable size in China belong to the *C. longulus* species group: *C. moureauxae* Perreau 1990, *C. curvipes* Perreau 1990 and *C. nikodymi* Růžička 1993 (4.8–5.6 mm; Perreau 1990, Růžička 1993).

Catops nigricans (Spence 1813)

Choleva nigricans Spence 1813: 141 (description; type locality: [Great Britain]).

Catops nigricans: Sturm 1839: 19 (new combination).

Catops nigricans: Jeannel 1936: 372, 402 (key, distribution).

Catops nigricans: Zwick 1981: 37 (redescription, distribution).

Catops nigricans: Perreau 2000: 123 (catalogue, distribution).

Catops nigricans: Perreau 2004: 139 (catalogue, distribution).

Material examined. China: Xinjiang Uygur autonomous region: 1 ♂ (JVAC), labelled “Ch[ina], Xinjiang, SSE Tekes / Narat MR [mountain range], l. b-k [left bank of] Ural R. [river] / =trib. [tributary] Kshi-Kushtai [ca. 42°47'N 082°04'E] / 3100–3150 m, 16.6.1999 / Belousov & Kabak leg.”.

Diagnosis. Small, compact species (body size only 4.1 mm) with distinctly convex elytra. Male can be safely recognised by its trapezoidal, dorso-ventrally flattened apex of the aedeagus with a distinct median dent and a shallow, weak dorsal depression, compact and oval genital segment (fig. 43) and apically emarginate posterior margin of ventrite VIII (fig. 40). Female can be recognised by its subtriangular tergum VIII (fig. 16), short and narrowly rounded spiculum ventrale with a shallow median depression (fig. 20) and oval shape of tergite IX (fig. 8).

Redescription. Total body length 4.1 mm. Combined length of pronotum and elytra 3.7 mm. Combined maximum width of elytra 1.9 mm.

Body smaller, compact (fig. 4), uniformly dark brown with lighter brown legs. Antenna light brown with antennomeres VII–X darker.

Head: surface distinctly and densely punctate. Distance between punctures ca. 1.0–1.5 times their diameter, surface with fine transverse microsculpture. Head covered by adpressed, short yellow setation. Eyes of normal size. Antenna elongate; antennomeres IX–XI round and compact; antennomere VIII only slightly transverse (fig. 26), less transverse than in specimens from central Europe (figs. 27, 28); antennomere XI compact (fig. 26).

Pronotum: relatively small, less transverse, ca. 1.45 times as wide as long, elytra ca. 1.25 times as wide as pronotum. Pronotum widest before the middle of lateral margin, sides evenly rounded, constricted posteriorly, hind angles acute. Posterior margin with narrow and shallow but distinct lateral emargination (fig. 4). Surface of pronotum regularly convex, punctation finer than that on head, setation and microsculpture as that on head.

Elytra: oval, ca. 1.35 times as long as wide, distinctly convex. Apex of each elytron rounded both in male and female. Hind wings fully developed.

Protibia relatively narrow, gradually expanding toward apex in male (fig. 35); basal protarsomere in male only slightly broader than apex of protibia. Basal mesotarsomere widened in male but narrower than apex of mesotibia; meso- and metatibia regularly curved.

Male genitalia. Ventrite VIII posteriorly elongate with narrow emargination (fig. 40). Genital segment: spiculum gastrale widely triangular, only moderately elongate anteriorly and

vestigial posteriorly; genital plate widely oval, rounded posteriorly; tergum narrow, rounded ventro-apically (fig. 43). Aedeagus with moderately wide median lobe in ventral view, wide and with narrow and straight apex in lateral view (Jeannel 1936: 371, fig. 950). Apex of median lobe trapezoidal, narrowing to truncate apex with distinct apical median dent, dorsally with shallow, weakly delimited depression (Jeannel 1936: 371, fig. 950). Internal sac with narrow, sharply pointed, sclerotized, reversed V-shaped subapical dent. Valves of genital orifice rounded apically. Parameres thickened only basally.

Female genitalia. Tergum VIII subtriangular, truncate posteriorly, with small and rounded median desclerotization (fig. 16). Ventrite VIII with laterally undulate posterior margin, spiculum ventrale short, narrowly rounded, with shallow median depression (fig. 20). Tergite IX elongate oval, with three pairs of larger setae and numerous other small setae posteriorly (fig. 8). Epipleurite IX without separated postero-lateral region (fig. 12). Coxite with only three subapical, one lateral and one basal large setae, without additional small setae (fig. 12). Ventral sclerite small, oval, sclerotized, with deep posterior emargination (fig. 12).

Note. As the only known Chinese specimen is a male, the description of the female terminalia is based on material from central Europe (Czech Republic: northern Bohemia).

Distribution. Widely distributed through Europe to Turkey (Perreau 2004); first record from China (Xinjiang Uygur autonomous region) (fig. 59).

Catops hlisnikovskyi n. sp.

Type material. Beijing municipality: Holotype ♂ (JRUC), labelled: "CHINA: Xiaolongmen [= Xiaolongmen National Forest Park near Shuangtangjian, ca. 39°58'N 115°26'E] / Beijing, 1100–1500 m / v. – vi. 1993 / G. de Rougemont [leg.] [p]"; 6 paratypes: 3 paratypes (3 ♀♀, JRUC), the same data; **Jiangsu province:** 3 paratypes (2 ♂♂, 1 ♀; NMPC), labelled: "Northwestl. China / Chinkiang [= Zhenjiang, ca. 32°08'N 119°30'E] [p] // Holotypus [or Paratypus] [p, red label] // CATOPS FUSCUS [male/female symbol] / s. REITTERI m. Holotypus [or Paratypus] [hw] / det. Hlisnikowski 19 [p] 70 [hw] [pink label]"; 1 paratype (1 ♂, MHNG): the same data.

Diagnosis. Large, oval species (fig. 6) with dark brown to black head and pronotum and distinctly paler elytra. It can be easily recognised from other species of the *Catops fuscus* species group from China by the distinctly transverse antennomeres VIII–X (figs. 31, 32) and protibia with outer margin with numerous spines in both sexes (figs. 37, 38). Males can also be distinguished by the very narrow, subapically sinuate aedeagus (figs. 46, 47) and robust paramere (fig. 47) in combination with the posteriorly V-shaped tergum of genital segment (fig. 45). Female can be characterized by the widely unsclerotized, transverse tergum VIII (fig. 18), triangular and sharply pointed spiculum ventrale (fig. 22) and three additional small lateral setae on coxite (fig. 14).

Description. Total body length 4.9–5.3 mm (5.1 mm in the HT). Combined length of pronotum and elytra 4.2–4.5 mm (4.4 mm in HT). Combined maximum width of elytra 2.1–2.2 mm (2.2 mm in HT).

Body elongate (fig. 6), head and pronotum dark brown to black, elytra and legs brown. Antenna dark brown with two

basal antennomeres and apical half of ultimate antennomere pale brown to yellowish.

Head: surface distinctly and densely punctate. Distance between punctures ca. 1.0–1.5 times their diameter, surface with distinctly developed transverse microsculpture. Head covered by longer adpressed to semierect golden setation. Eyes of normal size (fig. 6). Antenna elongate; antennomeres VIII–X distinctly transverse, subtrapezoid; antennomere XI very elongate (figs. 31, 32).

Pronotum: large, distinctly transverse, ca. 1.55–1.75 times (1.55 times in HT) as wide as long, elytra only 1.15–1.25 times (1.20 times in HT) as wide as pronotum. Pronotum widest at the middle of lateral margin, sides evenly rounded, only slightly constricted posteriorly, hind angles nearly rectangular. Posterior margin with wide and shallow but distinct postero-lateral emargination (fig. 6). Surface of pronotum regularly convex, punctuation finer than that on head, setation and microsculpture as that on head.

Elytra: subparallel in basal half, rounded and narrowed in apical half, ca. 1.30–1.35 times (1.30 times in HT) as long as wide, weakly convex. Apex of each elytron almost rectangular in male, tapered into slightly rounded, sub-acute tip in female. Hind wings fully developed.

Protibia wide, gradually expanding toward apex in male, outer margin with distinct, numerous spines in both sexes (figs. 37, 38); basal protarsomere in male as wide as apex of protibia. Basal mesotarsomere weakly widened in male, distinctly narrower than apex of mesotibia, mesotibia regularly curved, metatibia almost straight.

Male genitalia. Ventrite VIII posteriorly regularly rounded. Genital segment: spiculum gastrale narrow and only moderately elongate anteriorly, narrow and elongate also posteriorly; genital plate oval, rounded posteriorly; tergum narrow, V-shaped ventro-apically (fig. 45). Aedeagus with narrow median lobe in ventral view (fig. 47), narrow, regularly rounded and sinuate subapically in lateral view (fig. 46). Apex of median lobe narrow, tapered to triangular tip with prominent and elevated dentate lobe (fig. 54) with apical emargination in dorso-apical view. Internal sac with narrow, reverse V-shaped sclerotized structure located at two-thirds of the length of median lobe (fig. 47). Valves of genital orifice with acute apices. Parameres thick (fig. 47).

Female genitalia. Tergum VIII transverse, widely truncate posteriorly; with large trapezoidal desclerotization medially (fig. 18). Ventrite VIII with simple but complete posterior margin; spiculum ventrale short, triangular, sharply pointed anteriorly (fig. 22). Tergite IX short, pentagonal in shape, with dense posterior setation (fig. 10). Epipleurite IX with well-developed and distinctly separated postero-lateral sclerotized region (fig. 14). Coxite with three subapical and one lateral large setae and three additional small lateral setae (fig. 14). Ventral sclerite very weakly sclerotized, truncate posteriorly; with widely oval, irregularly sclerotized anterior pattern (fig. 14).

Etymology. Patronymic, named in honour of the late Josef Hlisnikovský (1905–1972), who was the first to recognise the species, although he did not formally describe it. He was a professor of mining mechanization on Minning College, Ostrava, and Technical College, Košice. However, he was also early interested in taxonomy of beetles, especially Silphidae, Agyrtidae and Leiodidae, on a worldwide level. In parallel with his technical career, he published over 60 publications in entomology between 1929 and 1974 (with last four papers published posthumously) (Jelínek 1973).

Collecting circumstances. Not known.

Distribution. Known only from two localities in eastern China (Beijing municipality and Jiangsu province) (fig. 59).

Catops sasajii Nishikawa 2007

Catops sasajii Nishikawa 2007: 47 (description; type locality: China: Shaanxi province, Daba Shan mts, Ten'ya village env., 31°55'N 109°05'E, 2200–2600 m).

Material examined. China: Hubei province: 1 ♂ (subteneral) (NHMB), labelled: “CHINA, W HUBEI prov. / Dashennongjia Nat. Res. / Muyu [= Muyuping], E slope, 2000 m [ca. 31°30'N 110°21'E] / 12-16 Jun 1997, Bolm lgt.”; **Shaanxi province:** 14 ♂♂, 13 ♀♀ (APUC), labelled: “China: Shaanxi, Qin Ling Shan / 107.56E, 33.45N, Autoroute km / 93 S of Zhouzhi, 108 km SW Xian / Mountain Forest, sifted, 1850 m / 1.-2.09.1995, leg. A. Pütz [p] // coll. / A. Pütz [p]”; 2 ♂♂, 2 ♀♀ (JRUC), the same data; 1 ♂, 1 ♀ (MPEC), the same data; 3 ♂, 2 ♀ (MSCC), the same data except for: “leg. M. Schülke [p] // Sammlung / M. Schülke / Berlin [p, green label]”; 1 ♂, 1 ♀ (JRUC), the same data; 2 ♀♀ (NMEG), the same data except for: “1650m, 1.-2.IX. [19]95 Wrase [leg., p]”; 1 ♂, 2 ♀♀ (MSCC), labelled: “CHINA: S-Shaanxi (Qinling Shan) / pass on rd. Zhouzhi – Foping / 105 km SW Xi'an, N slope / 1990 m, 33°44' N 107°59' E / leg. M. Schülke (C01-01) // 2./4. VII. 2001, / small creek valley, mixed / deciduous forest, bamboo, / small meadows, dead wood, / mushrooms (sifted) (C01-01) [p]”; 1 ♀ (JRUC), labelled: “CHINA Shaanxi Qinling / Shan pass rd. Zhouzhi / Foping 105km SW Xi'an // N-slope 1990 m 33°44'N / 107°59'E 2. VII. 2001 / A. Smetana [leg.] (C89) // mixed deciduous forest, / sifting of various debris, / leaf litter etc. of the forest / floor, close to a small brook [p]”; 1 ♀ (JRUC), labelled: “Qinling Shan mts., 6 km / S of Xunyangba, / ca. 33°28'N 108°30'E, / 18.V.-3.VII. 2005, / Oto Naklálal leg. // on the first mountain / ridge S of Xunyangba, / wet close valley near / the stream, secondary / mixed forest, unbaited / pitfall traps [p]”; **Sichuan province:** 1 ♀ (JRUC), labelled: “China, Sichuan prov. / 15km N of SABDE / 3-4.VIII. 1992, 2500 m / R. Sauer lgt. // 29°38'N 101°43'E / pitfall trap (fish) / deciduous forest [p]”; 1 ♀ (MHNG), labelled: “CHINA Sichuan / Wolong Natur. Res. [ca. 30°58'N 103°06'E] / 900 m litter / 23. V. [19]94 Kurbatov [leg., p]”; 1 ♀ (JRUC), labelled: “CHINA: SICHUAN (12-14) / rd. WOLONG to DENGSHENG / 2140–2200 m / VI-VII 2007”; 1 ♀ (JRUC), labelled: “CHINA: SICHUAN (11) / rd. WOLONG to DENGSHENG / env. WOLONG 2050 m / VI-VII 2007”; 2 ♂♂ (MSCC), labelled: “CHINA: W-Sichuan (7) / Daxue Shan, W Kangding / 30.03.13N, 101.57.11E / 2700–2800 m / 24.05.1997, M. Schülke [leg.] [p]” // Sammlung / M. Schülke / Berlin [p]”; 1 ♂ (AWAC), labelled “CHINA (W Sichuan) / Daxue Shan, Hailuogou / Glacier Park (Gongga / Shan) Camp 1, 2100 m / 29.38 N / 102.04 E / 27./28./31.V. [19]97 Wrase [leg.] [p]”; 1 male (JRUC), labelled “CHINA: W Sichuan / 20 km N Sabdé, 3200 m / 29°35'N 101°23'E 10-16. / VII. 1998 D. Král [leg.] [p] // rotten fungi [hw]”; 1 ♀ (JRUC), the same data except for “102[correctly: 101]°23'E 12.VII. / 1998, A. Smetana [leg.] (C78) // remnant of an original forest / (*Abies*, *Pinus*, *Betula*, / *Populus*) along a river // sifting of ground / mushrooms (fresh and in / various degree of rotting) / and debris around them [p]”; 1 ♀ (JRUC), the same data except for “102[correctly: 101]°23'E 14.VII. / 1998, A. Smetana [leg.] (C81) // remnant of an original forest / (*Abies*, *Pinus*, *Betula*, / *Populus*) along a

river; / sifting soil and debris under / a dog carcass [p]”; **Yunnan province:** 1 ♀ (head and pronotum missing) (JRUC), labelled: “CHINA, YUNNAN prov. / HEISHUI 35 km N Lijiang / 18.6.-4.7.1993 / 27[°], 13['] N ; 100[°], 19['] E / lgt.S.Becvar [p]”; 1 ♀ (JVAC), labelled: “CHINA-W, YUNNAN / Dequen [= Dêqên, ca. 28°28'N 098°48'E] / 15-18.7.2002 / Lgt.E.Kučera [p]”; 1 ♀ (MPEC), labelled “CHINA: N-Yunnan Zhong- / dian Co. 36km ESE Zhong- / dian, 27°40.9'N 100°01.5'E / 3500–3550 m 23.VIII.2003 / A. Smetana [leg.] (C133) // remnant of an original mixed / forest (*Abies*, *Acer*, *Betula*, / rhododendrons), plenty of / rotting wood and fallen trees / on the floor // sifting of leaf litter, moss and / various debris under fallen / trees and around them, / around tree stumps and in / depressions of forest floor [p]”.

Diagnosis. Easily characterized by the very elongate and large body (fig. 5; body size 5.3–6.3 mm), which makes it the largest species within the Chinese members of the *Catops fuscus* species group. Characteristic is also the very elongate antenna with large oblong antennomeres VII, IX and X and a distinctly asymmetrical antennomere VIII (figs. 29, 30). Males can be recognised by the relatively slender aedeagus with dorso-ventrally curved apical part (fig. 50), forming a subrectangular and relatively narrow apex (fig. 56) – apex is broader in dorsal view and straight in lateral view in the related *C. schuelkei* n. sp. and *C. smetanai* n. sp. (figs. 55, 57). Males can be also well characterized by the elongate posterior margin of ventrite VIII (fig. 39), long and wide anterior part of spiculum gastrale and angulate genital plate on the genital segment (fig. 44); the spiculum gastrale is narrow in both *C. schuelkei* n. sp. and *C. smetanai* n. sp. (figs. 41, 42) and the genital plate is rounded in *C. schuelkei* n. sp. (fig. 41). Females can also be characterized by the posteriorly widely emarginate tergum VIII (fig. 17; as in *C. schuelkei* n. sp.), very elongate and widely rounded spiculum ventrale (fig. 21), elongate and posteriorly wide but anteriorly distinctly narrowing tergite IX (fig. 9) and the presence of numerous additional small dorsal and lateral setae on the coxite (fig. 13).

Redescription. Total body length 5.3–6.3 mm. Combined length of pronotum and elytra 4.7–5.2 mm. Combined maximum width of elytra 2.2–2.4 mm.

Body very elongate and slender (fig. 5), head dark brown to black, rest of body and legs brown. Antenna light brown with antennomeres VII–X darker.

Head: surface distinctly and densely punctate. Distance between punctures ca. 1.0–1.5 times their diameter, surface with distinctly developed transverse microsculpture. Head covered by longer semierect golden setation. Eyes large, laterally protruding (fig. 5). Antenna very elongate; antennomeres VII, IX and X very large, oblong; antennomere VIII asymmetrical, transverse; antennomere X very elongate (figs. 29, 30).

Pronotum: distinctly transverse, ca. 1.55–1.65 times as wide as long, elytra 1.20–1.30 times as wide as pronotum. Pronotum widest at basal two-fifths to middle of lateral margin, sides evenly rounded, distinctly constricted posteriorly, hind angles acute and elongate. Posterior margin with narrow and deep postero-lateral emargination (fig. 5). Surface of pronotum regularly convex but flattened postero-laterally, punctation finer than that on head, golden setation erect, microsculpture as that on head.

Elytra: very elongate, ca. 1.45–1.60 times as long as wide, weakly convex. Apex of each elytron rounded in male, subacute or rarely pointed in female. Hind wings fully developed.

Protibia wide, gradually expanding toward apex in male (fig. 36); basal protarsomere in male very wide, distinctly broader than apex of protibia. Basal mesotarsomere widened in male, as wide as apex of mesotibia, meso- and metatibia regularly curved.

Male genitalia. Posterior margin of ventrite VIII produced medially (fig. 39). Genital segment: spiculum gastrale wide and elongate anteriorly, wide and tri-lobed posteriorly; genital plate robust, elongate, angulate postero-laterally; tergum wide, rounded ventro-apically (fig. 44). Aedeagus with moderately wide median lobe in ventral view (fig. 51), wide and with apex dorsally curved in lateral view (fig. 50). Apex of median lobe narrowing to a quadrangular, truncate apex with sinuous anterior outline (fig. 56). Internal sac with wide, reverse V-shaped subapical sclerotized structure (fig. 56). Valves of genital orifice rounded apically. Parameres thickened only basally (fig. 51).

Female genitalia. Tergum VIII widely emarginate posteriorly with trapezoidal desclerotization at posterior margin (fig. 17). Ventrite VIII with laterally undulate posterior margin; spiculum ventrale very elongate, widely rounded anteriorly (fig. 21). Tergite IX elongate, broadly oval posteriorly; with two pairs of larger and numerous small setae posteriorly (fig. 9). Epipleurite IX with only small, imperfectly separated postero-lateral regions (fig. 13). Coxite with four subapical and two lateral large setae and numerous additional small dorsal and lateral setae (fig. 13). Ventral sclerite subparallel, rounded posteriorly, weakly sclerotized with anterior longitudinal sclerotized pattern (fig. 13).

Variability. The male from Gongga Shan differs slightly in the shape of the tip of aedeagus, which is more curved dorsally and has a more laterally expanded apex. However, the male is subteneral and more specimens are needed to evaluate the variability in the shape of the aedeagus.

Collecting circumstances. Most of the specimens were sifted, taken with pitfall traps in different types of forests and attracted to rotten fungi or carrion at altitudes between 1850 and 3500 m. A few specimens were taken at only 900 m.

Distribution. Described from a single locality in southern Shaanxi province (Nishikawa 2007). Based on the specimens examined here, it seems to be widely distributed through central China from the northern part of the Yunnan province and the south-western part of the Sichuan province to the Qingling Shan mountains in the southern part of the Shaanxi province and the eastern part of the Daba Shan mountains in the west of the Hubei province (fig. 59). Here we provide the first records from the Hubei, Sichuan and Yunnan provinces.

Catops schuelkei n. sp.

Type material. China: Yunnan province: Holotype ♂ (MSCC), labelled "CHINA: N-Yunnan (C2005-09) / Diqing Tibet Aut. Pref. / Deqin Co., Meili Xue Shan [mts], / E-side, 14 km W Deqin, 2580 m, // 28°27.47'N 98°46.35'E, creek / valley below glacier, mixed forest, / leaf litter, moss, dead wood, sifted, 11.VI.2005, M. Schülke [leg.] (C2005-09) [p]"; 9 paratypes: 2 paratypes (2 ♂♂, subteneral; MSCC), the same data; 1 paratype (1 ♂, subteneral; MSCC), labelled "CHINA: N-Yunnan (C2005-07) / Diqing Tibet Aut. Pref. / Deqin Co.,

Meili Xue Shan [mts], E-side, / 12 km SW Deqin, 2890 m, / 28°25.30'N 98°48.47'E, // small creek valley, fixed forest / with bamboo, leaf litter, moss, / dead wood, sifted, 9.VI.2005, / leg. M. Schülke (C2005-07) [p]"; 1 paratype (1 ♂, subteneral; JRUC); the same data; 1 paratype (1 ♀, subteneral; JRUC), the same data except for "C2005-07A ... 13.VI.2005"; 1 paratype (1 ♂, subteneral; MPEC), labelled "CHINA: N-Yunnan Diqing Tibet / Aut.Pr. Deqin Co. Meili Xue / Shan E-side 12km SW Deqin / 28°25.30'N 98°48.47'E 2890 m / 9.VI.2005 A. Smetana [leg.] (C156) // small valley of a small creek / in a broadleaved forest with / bushy undergrowth; sifting / leaf litter, dead wood and / other debris along the creek [p]"; 1 paratype (1 ♂, subteneral; MPEC), the same data except for "13.VI.2005 ... (C160) // small valley of a small creek / in a broadleaved forest with / bushy undergrowth; sifting / leaf litter and other debris / along the creek [p]"; 1 paratype (1 ♀, MPEC), labelled "CHINA: N-Yunnan Diqing Tibet / Aut.Pr. Deqin Co. Meili Xue / Shan E-side 14 km W Deqin / 28°27.47'N 98°46.35'E 2580m / 11.VI.2005 A. Smetana [leg.] (C158) // seepages in a mixed forest / (*Abies, Acer, Betula*); sifting / of wet leaf litter and various / debris around and in / seepages [p]"; **Sichuan province:** 1 paratype (1 ♀, JRUC), labelled "CHINA: SE Sichuan [province] / Jinfo Shan [mts], 29°01[']N / 107°14[']E, 1800 m, 27.VI. / 1998, A. Smetana [leg.] (C70) // mixed broadleaved forest, / sifting of moist to wet leaf / litter and other debris along / bases of vertical rock walls [p].

Diagnosis. Medium-sized, rather slender species (figs. 1, 2), habitually similar and probably related to *C. smetanai* n. sp. and *C. sasajii* (figs. 3, 5); sharing with them also a very elongate antenna (figs. 23, 24) and distinctly broader protarsi than the apex of male protibia. The male is characterized by a very robust aedeagus (fig. 48) with a rounded apex (fig. 55); the apex is more rectangular in *C. sasajii* and *C. smetanai* n. sp. (figs. 56, 57). Moreover, the posterior margin of ventrite VIII is regularly rounded in males (elongate in *C. sasajii*, fig. 39) and the anterior part of spiculum gastrale is short and narrow (fig. 41). The anterior part of spiculum gastrale is narrow but more elongate in *C. smetanai* n. sp. (fig. 42) and elongate and wide in *C. sasajii* (fig. 44). Females can be characterized by a short and wide spiculum ventrale and rounded posterior margin of ventrite VIII (fig. 19) and a short, broadly oval tergite IX (fig. 7). The female of *C. smetanai* n. sp. is unknown. In *C. sasajii*, the spiculum ventrale is much more elongate and ventrite VIII is posteriorly undulate (fig. 21) and more elongate and anteriorly narrow tergite IX (fig. 9).

Description. Total body length 4.6–5.3 mm (5.0 mm in the HT). Combined length of pronotum and elytra 4.3–4.6 mm (4.3 mm in the HT). Combined maximum width of elytra 2.0–2.3 mm (2.0 mm in the HT).

Body elongate (fig. 1, 2), uniformly dark brown, legs brown. Antenna dark brown, with six basal antennomeres and apical half of ultimate antennomere pale brown to yellowish.

Head: surface distinctly, very densely punctate. Distance between punctures ca. 0.5–1.5 times of their diameter, surface with distinctly developed transverse microsculpture. Head covered by longer and semierect golden setation. Eyes of normal size. Antenna very elongate; antennomeres VII, IX and X large, subtrapezoidal; antennomere VIII distinctly transverse, symmetrical; antennomere XI elongate (figs. 23, 24).

Pronotum: distinctly transverse, ca. 1.40–1.65 times (1.45 times in HT) as wide as long, elytra 1.15–1.30 times (1.15

times in HT) as wide as pronotum. Pronotum widest at basal two-fifths of lateral margin, sides evenly rounded, distinctly constricted posteriorly, hind angles obtuse. Posterior margin almost straight or with narrow and very shallow postero-lateral emargination (fig. 1, 2). Surface of pronotum regularly convex, punctation finer than that on head, setation and microsculpture as that on head.

Elytra: oval, ca. 1.35–1.50 times (1.50 times in HT) as long as wide; weakly convex. Apex of elytron sub-rectangular in male, sub-acute in female. Hind wings fully developed.

Protibia wide, expanding toward apex in male (fig. 33); basal protarsomere in male distinctly broader than apex of protibia. Basal mesotarsomere widened in male, slightly narrower than apex of mesotibia, meso- and metatibia regularly curved.

Male genitalia. Ventricle VIII posteriorly regularly rounded. Genital segment: spiculum gastrale very narrow and only moderately elongate anteriorly, short and triangular posteriorly; genital plate robust, elongate, regularly rounded postero-laterally; tergum narrow, rounded ventro-apically, distinctly undulate (fig. 41). Aedeagus with very wide, subapically laterally expanded medial lobe (fig. 49), very wide and with nearly straight sides before apex in lateral view (fig. 48). Apex of median lobe with wide and subtruncate apex with blunt apical dent (fig. 55). Internal sac with extremely wide and very robust reverse V-shaped subapical sclerotized structure, extending laterally to outline of median lobe (fig. 55). Valves of genital orifice with acute apices. Parameres thickened only basally (fig. 49).

Female genitalia. Tergum VIII widely emarginate posteriorly; with small desclerotized median and lateral areas near posterior margin (fig. 15). Ventricle VIII with simple and complete posterior margin; spiculum ventrale short, widely rounded anteriorly (fig. 19). Tergite IX short, broadly oval, with two pairs of large and numerous small setae posteriorly (fig. 7). Epipleurite IX with distinctly separated, slender, sclerotized postero-lateral region (fig. 11). Coxite with three subapical and two lateral large setae, without additional small setae (fig. 11). Ventral sclerite elongate, subovoid, with heavily sclerotized elongate anterior portion (fig. 11).

Etymology. Patronymic, named after Michael Schülke, a specialist in the Staphylinidae, in recognition of his enormous collecting effort leading to the discovery of numerous undescribed species of the Cholevinae in China.

Collecting circumstances. Most of the specimens were sifted in wet forests at altitudes between 1800 and 2890 m.

Distribution. Presently known only from three localities in China (Sichuan and Yunnan provinces) (fig. 59).

Catops smetanai n. sp.

Type material. **China: Yunnan province:** Holotype ♂ (MPEC), labelled “CHINA: N-Yunnan Zhong- / dian Co. 36 km ESE Zhong- / dian, 27°40.9'N 100°01.5'E / 3500–3550 m 23.VIII.2003 / A. Smetana [leg.] (C133) // remnant of an original mixed / forest (*Abies*, *Acer*, *Betula*, / rhododendrons), plenty of / rotting wood and fallen trees / on the floor // sifting of leaf litter, moss and / various debris under fallen / trees and around them, / around tree stumps and in / depressions of forest floor [p]”; **Sichuan province:** 1 paratype (1 ♂; JRUC), labelled “CHINA: W Sichuan / 20 km N Sabdé, 3200 m / 29°35'[N

102[correct: 101]°23[']E 12.VII. / 1998, A. Smetana [leg.] (C78) // remnant of an original forest / (*Abies*, *Pinus*, *Betula*, / *Populus*) along a river // sifting of ground / mushrooms (fresh and in / various degree of rotting) / and debris around them [p]”.

Diagnosis. Relatively robust, medium-sized species, habitually similar and probably related to *C. sasajii* and *C. smetanai* n. sp. – see above for the shared characters. The male can be distinguished by the shape of the aedeagus, which is quite robust in lateral view (fig. 52) but more slender than in *C. schuelkei* n. sp. (fig. 48). The apex of aedeagus is wide and subtruncate with rounded antero-lateral angles and broad and distinct median emargination (fig. 57); it is more slender and not emarginate in *C. sasajii* (fig. 56) and distinctly convex in *C. schuelkei* n. sp. (fig. 55). Moreover, the anterior part of the genital plate is narrow and elongate and the posterior part of the tergum is weakly V-shaped (fig. 42); the genital plate is elongate and wide in *C. sasajii* (fig. 44) and narrow but shorter in *C. schuelkei* n. sp. (fig. 41) and the tergum of the genital sclerite is regularly rounded in both these species (figs. 41, 44). Female of *C. smetanai* n. sp. is presently unknown.

Description. Total body length 5.0 and 5.4 mm (5.0 mm in HT, head retracted). Combined length of pronotum and elytra 4.6 and 4.8 mm (4.8 mm in HT). Combined maximum width of elytra 2.2 and 2.3 mm (2.3 mm in HT).

Body more robust, oblong (fig. 3), uniformly dark brown, legs dark brown. Antennae dark brown, with six basal antennomeres and apical half of ultimate antennomere pale brown to yellowish.

Head: surface distinctly and very densely punctate. Distance between punctures ca. 0.5–1.5 times of their diameter, surface with distinctly developed transverse microsculpture. Head covered by longer semierect golden setation. Eyes of normal size. Antenna very elongate; antennomere VII oblong; antennomeres IX–X large, subtrapezoidal; antennomere VIII transverse, symmetrical; antennomere XI elongate (fig. 25).

Pronotum: large, less transverse, only ca. 1.45 (HT) and 1.55 times as wide as long, elytra ca. 1.15 and 1.25 (HT) times as wide as pronotum. Pronotum widest at basal two-fifths to middle of lateral margin, sides evenly rounded, distinctly constricted posteriorly, hind angles obtuse. Posterior margin slightly sinuous, almost straight postero-laterally (fig. 3). Surface of pronotum regularly convex, punctation finer than that on head, setation and microsculpture as that on head.

Elytra: widely oval, ca. 1.40 (HT) and 1.50 times as long as wide, weakly convex. Apex of each elytron rounded in male (female unknown). Hind wings fully developed.

Protibia wide, gradually expanding toward apex in male (fig. 34); basal protarsomere in male very wide, distinctly broader than apex of protibia. Basal mesotarsomere widened but narrower than apex of mesotibia in male, mesotibia regularly curved, metatibia almost straight.

Male genitalia. Ventricle VIII posteriorly regularly rounded. Genital segment: spiculum gastrale very narrow and elongate anteriorly, short and triangular posteriorly; genital plate robust, elongate, angulate postero-laterally; tergum wide, slightly produced ventro-apically (fig. 42). Aedeagus with moderately wide median lobe in ventral view (fig. 53), very wide and nearly straight below apex in lateral view (fig. 52). Apex of median lobe slightly broadened, anterior margin widely and shallowly emarginate without distinct apical dent (fig. 57). Internal sac with extremely wide and very robust, apically thickened, reverse V-shaped sclerotized subapical structure, reaching laterally to

outline of median lobe (fig. 57). Valves of genital orifice with acute apices.

Female genitalia. Unknown.

Etymology. Patronymic, named after Aleš Smetana, a specialist in the Staphylinidae, in recognition of his enormous collecting effort leading to the discovery of numerous undescribed species of the Cholevinae in China.

Collecting circumstances. Both specimens were sifted from substrate in primary forests at altitudes between 3200 and 3550 m.

Note. Both specimens were collected syntopically with *C. sasajii*.

Distribution. Presently known only from two localities in China (Yunnan and Sichuan provinces) (fig. 59).

Key to the Chinese species of the *Catops fuscus* species group

1. Small, compact species (body size only 4.1 mm), with narrow pronotum and distinctly convex elytra (fig. 4). Male with trapezoidal apex of aedeagus with

shallow, weak depression dorsally (Jeannel 1936: 371, fig. 950); male ventrite VIII posteriorly elongate, with narrow emargination (fig. 40). Female with tergum VIII subtriangular (fig. 16); spiculum ventrale short and narrowly rounded with shallow median depression (fig. 20); tergite IX oval (fig. 8) (Xinjiang Uygur autonomous region) *C. nigricans* (Spence)

- Larger, more elongate species (body size 4.9–6.3 mm), with much wider pronotum and more flattened elytra (figs. 1–3, 5, 6). Male with apex of aedeagus either very narrow (fig. 54) or rounded to subtruncate in ventral view (figs. 55–57); male ventrite VIII simple, without posterior emargination. Female with transverse tergum VIII (figs. 15, 17–18), spiculum ventrale without median depression (figs. 19, 21–22) (female unknown in *C. smetanai* n. sp.) 2

2. Large species (body size 4.9–5.3 mm) with bicoloured body (head and pronotum dark brown to black, elytra paler); antennae with distinctly transverse antennomeres VIII–X (figs. 31, 32) and protibia with outer margin with numerous spines in both sexes (figs. 37, 38). Male with very narrow aedeagus in ventral view; paramere

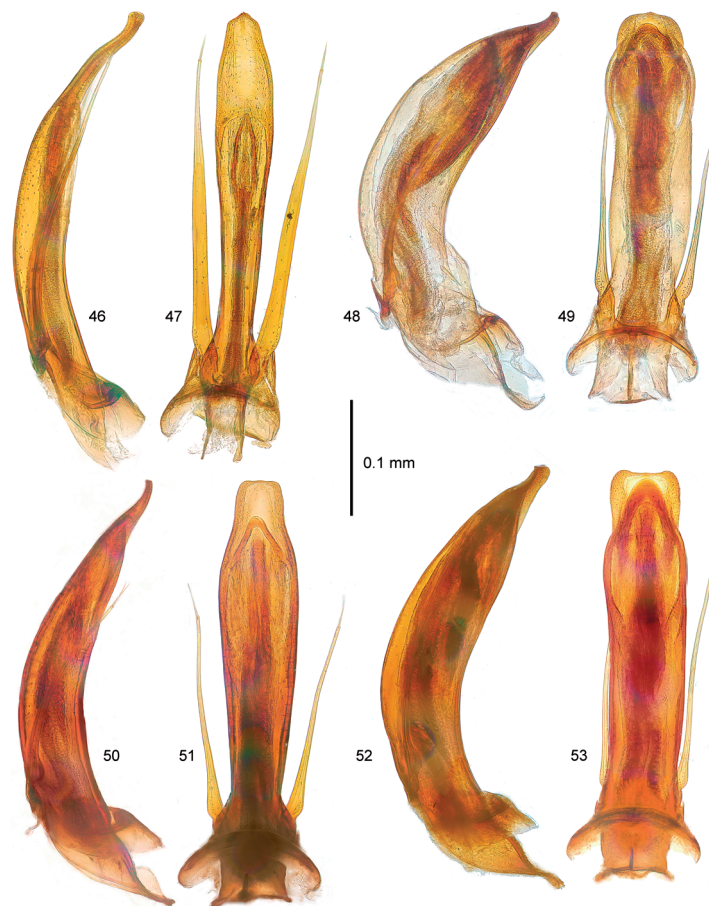

Figures 46–53

Aedeagus, lateral and ventral view. 46–47, *Catops hlisnikovskyi* n. sp., holotype (JRUC). 48–49, *C. schuelkei* n. sp., holotype (MSCC). 50–51, *C. sasajii* Nishikawa (93 km S Zhouzhi, JRUC). 52–53, *C. smetanai* n. sp., holotype (MPEC).

- robust (fig. 47); tergum of genital segment V-shaped posteriorly (fig. 45). Female with tergum VIII truncate posteriorly (fig. 18); spiculum ventrale triangular, sharply pointed (fig. 22); tergite IX short, pentagonal (fig. 10); three additional small setae present laterally on short coxite (fig. 14) (Beijing municipality, Jiangsu province) *C. hlisnikovskiyi* n. sp.
- Large to very large species (body size 4.6–6.3 mm) with uniformly brown to dark brown body; antennae with antennomeres VII and IX–X very large, oblong to subtrapezoidal, antennomere VIII distinctly narrower (figs. 23–25, 29–30); protibia with outer margin without spines (figs. 33–36). Male with broader aedeagus in ventral view and slender paramere, at least in distal half (figs. 49, 51, 53); tergum of genital segment regularly rounded posteriorly (figs. 41, 44–45) or only slightly V-shaped ventro-apically (fig. 42). Female (unknown in *C. smetanai* n. sp.) with tergum VIII widely emarginate posteriorly (figs. 15, 17); spiculum ventrale rounded (figs. 19, 21); tergite IX wide and oval (figs. 7, 9); coxite elongate (figs. 11, 13) (Hubei, Shaanxi, Sichuan and Yunnan provinces) 3
3. Very large species (body size 5.3–6.3 mm) with large eyes, elongate elytra (fig. 5) and antennae (figs. 29–30). Male with relatively slender aedeagus, its apex dorso-ventrally curved in lateral view (fig. 50) and subtruncate and relatively narrow in ventral view (fig. 56); posterior margin of ventrite VIII elongate (fig. 39); anterior part of spiculum gastrale of genital segment long and wide (fig. 44). Female with very elongate, widely rounded spiculum ventrale (fig. 21); tergite IX elongate, posteriorly wide but anteriorly distinctly narrowing (fig. 9); numerous additional small setae present dorsally and laterally on coxite (fig. 13) (Hubei, Shaanxi, Sichuan and Yunnan provinces) *C. sasajii* Nishikawa
- Large species (body size 4.6–5.4 mm) with normally-sized eyes, more oval elytra (figs. 1–3) and slightly shorter antennae (figs. 23–25). Male with broad aedeagus with apex straight in lateral view (figs. 48, 52) and broad in ventral view (figs. 55, 57); posterior margin of ventrite VIII rounded and anterior part of spiculum gastrale on genital segment slender (figs. 41–42). Female with shorter, rounded spiculum ventrale (fig. 19) and short, broadly oval tergite IX (fig. 7) (female unknown in *C. smetanai* n. sp.) (Sichuan and Yunnan provinces) 4
4. Body size 4.6–5.3 mm, pronotum distinctly transverse (figs. 1–2). Aedeagus very robust in lateral view (fig. 48) and with rounded apex in ventral view (fig. 55); anterior part of spiculum gastrale on genital segment short (fig. 41). Female with shorter, rounded spiculum ventrale (fig. 19) and short, broadly oval tergite IX (fig. 7) (Sichuan and Yunnan provinces) *C. schuelkei* n. sp.
- Body size 5.0–5.4 mm, pronotum more robust, less transverse (fig. 3). Aedeagus robust in lateral view (fig. 52), apex subtruncate and distinctly emarginate in ventral view (fig. 57); anterior part of spiculum gastrale on genital segment large in male (fig. 42). Female unknown. (Sichuan and Yunnan provinces) *C. smetanai* n. sp.

Phylogeny

Preliminary phylogenetic analysis resulted in a single tree (length 38, consistency index 78 and retention index 57) (fig. 58). The Chinese representatives of the *Catops fuscus* species group seem to be separated into two clades, (1) *C. hlisnikovskiyi* n. sp. + *C. fuscus* and (2) the remaining species with the following branching pattern: *C. nigricans* + (*C. sasajii* + (*C. schuelkei* n. sp. + *C. smetanai* n. sp.)). The bootstrap support is low (below 50%), but we believe that a more complex analysis including all Palearctic species of this species group should confirm the validity of the two clades hypothesized here.

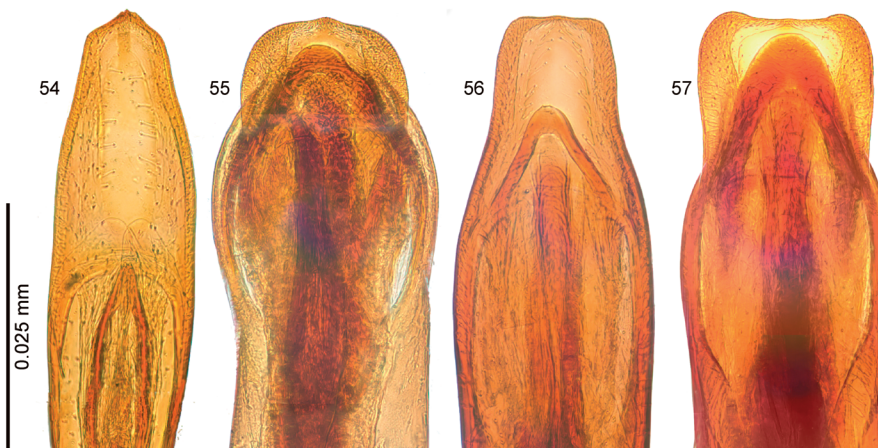

Figures 54–57
Aedeagus, apex of median lobe, ventral view. **54**, *Catops hlisnikovskiyi* n. sp., holotype (JRUC). **55**, *C. schuelkei* n. sp., holotype (MSCC). **56**, *C. sasajii* Nishikawa (93 km S Zhouzhi, JRUC). **57**, *C. smetanai* n. sp., holotype (MPEC).

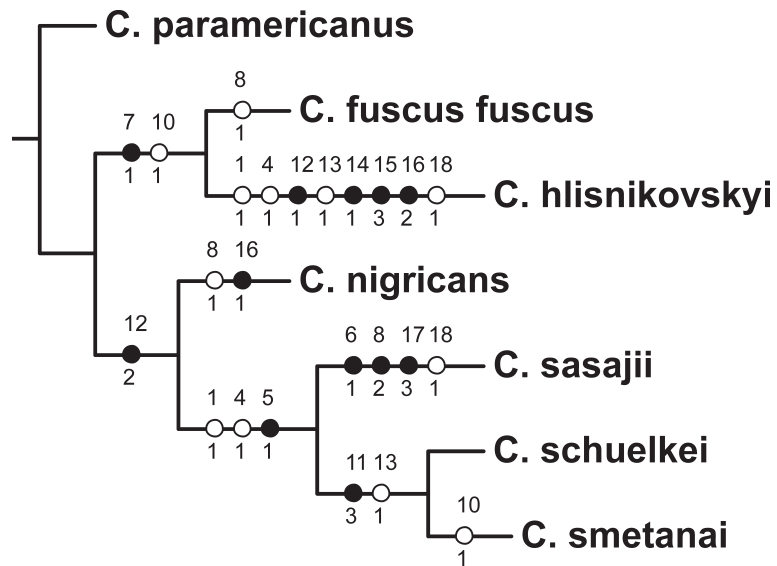

Figure 58

Preliminary phylogeny of the Chinese species of the *Catops fuscus* species group with *Catops paramericanus* Peck & Cook selected as outgroup. Only unambiguously optimized evolutionary events are mapped. Closed circles represent unique evolutionary events, open circles represent convergencies or subsequent reversals. Character numbers are given above, character states below.

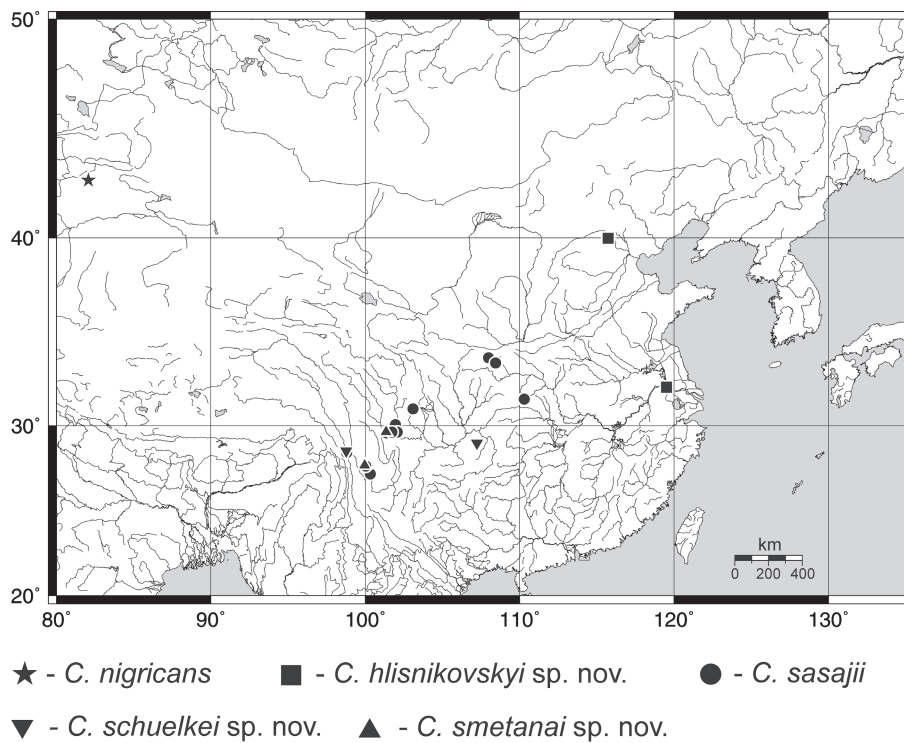

Figure 59

Distribution of *Catops fuscus* species group throughout China.

Zoogeography

Chinese representatives of the *Catops fuscus* species group have a distinct zoogeographical pattern (fig. 59). The Western Palaearctic *C. nigricans* reaches the north-westernmost part of China; whereas *C. hlisnikovskyi* **n. sp.** is probably distributed along the (north)-eastern littoral zone.

The remaining three species (*C. sasajii*, *C. schuelkei* **n. sp.** and *C. smetanai* **n. sp.**) form a cluster of closely related taxa distributed through mountain ridges in central China (northern Yunnan and Sichuan to southern Shaanxi and western Hubei provinces).

Taxonomical and distributional information accumulated here can be considered only as preliminary. Most probably, further species of this group will be discovered in the future, and it seems probable that the actual distribution of at least the species from central China is wider than presently known. All three species have possibly widely overlapping distribution; two of them, *C. sasajii* and *C. smetanai* **n. sp.**, were already collected syntopically.

Several species of *Catops fuscus* group are known from Nepal (J. Růžička, unpublished), but only *C. loebli* Perreau 1988 is named and formally described (Perreau 1988, 2000). Additional taxon, *C. fuscus repentinus* Szymczakowski 1962 is known from Japan (Szymczakowski 1962, Perreau 2000), and its subspecific assignment is also doubtful (J. Růžička, unpublished). Both questions are beyond of the scope of this paper.

Acknowledgements. We are obliged to S. Bečvář (České Budějovice, Czech Republic), M. Brancucci (NHMB), J. Cooter (Hereford, England), G. Cuccodoro (MHNG), J. Hájek (NMPC), M. Hartmann (NMEG), J. Jelínek (NMPC), I. Löbl (MHNG), A. Pütz (Eisenhüttenstadt, Germany), M. Schülke (Berlin, Germany), R. Sauer (Praha, Czech Republic), R. Schuh (Wiener Neustadt, Austria), A. Smetana (Ottawa, Canada), J. Vávra (Ostrava, Czech Republic) and A. Weigel (Pössneck, Germany) for the loan or donation of specimens. V. Kubáň (NMPC) kindly selected specimens from unidentified material and arranged its loan from MHNG. Aleš Smetana (Ottawa, Canada) kindly provided detailed information on collecting circumstances for specimens collected by him. D.S. Boukal (České Budějovice, Czech Republic) is thanked for linguistic help. We are thankful to H. Hoshina (Fukui, Japan), J. Fresneda (Llesp, Spain) and S. B. Peck (Ottawa, Canada) for the very helpful comments on the earlier version of the manuscript. This study was partly supported by the Grant Agency of the Czech Republic (grant 206/02/0266) to J. Růžička. The visit of J. Růžička to London was supported by SYNTHESYS Project GB-TAF-369 (<http://www.synthesys.info/>) financed by the European Community Research Infrastructure Action under the FP7 Integrating Activities Programme.

References

- Bameul F. 1990.** Le DMHF: un excellent milieu de montage en entomologie. *L'Entomologiste* **46**: 233-239.
- Deuve T. 2001.** The epipleural field in hexapods. *Annales de la Société Entomologique de France* (N. S.) **37**: 195-231.
- Fresneda J., Lencina J.L., Salgado J.M. 2006.** Descripción del primer *Catops* Paykull, 1798 endémico de la Península Ibérica: *Catops punctatulus* n. sp. (Coleoptera, Leiodidae, Cholevinae). *Nouvelle Revue d'Entomologie* **23**: 45-54.
- Goloboff P. 1999.** *NONA (NO NAME) ver. 2.0*. Published by the author, Tucumán, Argentina.
- Jeannel R. 1936.** Monographie des Catopidae (Insectes Coléoptères). *Mémoires du Muséum National d'Histoire Naturelle* (N. S.) **1**: 1-433.
- Jelínek J. 1973.** In memory of professor ing. Josef Hlisnikovský. *Acta Entomologica Bohemoslovaca* **70**: 430-432.
- Nishikawa M. 2007.** A New *Catops* (Coleoptera: Leiodidae: Cholevinae) from the Daba Shan Mountains of South Shaanxi, Central China. *The Entomological Review of Japan* **62**: 47-50.
- Nixon K.C. 2002.** *Winclada, Version 1.00.08*. Published by the author, Ithaca, New York.
- Peck S.B., Cook J. 2002.** Systematics, distributions, and bionomics of the small carrion beetles (Coleoptera: Leiodidae: Cholevinae: Cholevini) of North America. *The Canadian Entomologist* **134**: 723-787.
- Perreau M. 1988.** Les Cholevinae himalayens du Muséum d'Histoire naturelle de Genève. *Revue Suisse de Zoologie* **95**: 1005-1018.
- Perreau M. 1990.** Nouvelles espèces de Cholevinae de Chine (Col.). *Bulletin de la Société Entomologique de France* **94**: 273-281.
- Perreau M. 2000.** Catalogue des Coléoptères Leiodidae Cholevinae et Platypsyllinae. *Mémoires de la Société Entomologique de France* **4**: 1-460.
- Perreau M. 2004.** Family Leiodidae Fleming, 1821, p. 133-203 in: **Löbl I., Smetana A. (eds.), Catalogue of Palaearctic Coleoptera, Vol. 2: Hydrophiloidea – Histeroidea – Staphylinoidea**. Apollo Books, Steenstrup, 942 p.
- Růžička J. 1993.** *Catops nikodymi* sp. n. and notes on Cholevinae from China (Coleoptera, Leiodidae). *Acta Societatis Zoologicae Bohemoslovacae* **56**(1992): 279-284.
- Růžička J. 1995.** A new species of *Catops* and notes on Cholevinae (Coleoptera: Leiodidae) from Bulgaria. *Klapalekiana* **31**: 121-129.
- Salgado J.M., Blas M., Fresneda J. 2008.** Coleoptera, Cholevinae, in: **Ramos M.A. (eds.), Fauna Ibérica**. Volume 31. Museo Nacional de Ciencias Naturales & Consejo Superior de Investigaciones Científicas, Madrid, 799 p.
- Spence W. 1813.** A monograph of the British species of the genus *Choleva*. *The Transactions of the Linnean Society of London* **11**: 123-163.
- Sturm J. 1839.** *Deutschlands Fauna in Abbildung nach der Natur. V. Abtheilung. Die Insecten. Vierzehntes Banden. Käfer*. J. Sturm, Nürnberg, 123 p.
- Szymczakowski W. 1962.** Remarques sur quelques Catopinae du Japon. *Niponius* **1**(17): 1-7.
- Szymczakowski W. 1964.** Analyse systématique et zoogéographie des Catopidae (Coleoptera) de la région orientale. *Acta Zoologica Cracoviensis* **9**: 55-283.
- Topp W. 1990.** Selection for an optimal monovoltine life cycle in an unpredictable environment. Studies on the beetle *Catops nigricans* Spence (Col. Catopidae). *Oecologia* **84**: 134-141.
- Topp W. 2003.** Phenotypic plasticity and development of cold-season insects (Coleoptera: Leiodidae) and their response to climatic change. *European Journal of Entomology* **100**: 233-243.
- Zwick P. 1981.** *Catops nigricantoides* Reitter und *Catops andalusicus* Heyden, zwei verkannte europäische Arten (Coleoptera, Cholevinae). *Entomologische Blätter* **77**: 32-48.